

Hydrothermal Economic Dispatch Using Hybrid Big Bang-Big Crunch (HBB-BC) Algorithm

by Ys Akil

Submission date: 07-Sep-2022 10:13AM (UTC+0700)

Submission ID: 1894113660

File name: c_Dispatch_using_Hybrid_Big_Bang-Big_Crunch_HBB-BC_Algorithm.pdf (499.66K)

Word count: 2870

Character count: 14582

1

PAPER · OPEN ACCESS

3

Hydrothermal Economic Dispatch Using Hybrid Big Bang-Big Crunch (HBB-BC) Algorithm

4

To cite this article: Sokun Ieng *et al* 2019 *J. Phys.: Conf. Ser.* **1198** 052006

View the [article online](#) for updates and enhancements.



IOP | ebooks™

Bringing you innovative digital publishing with leading voices to create your essential collection of books in STEM research.

Start exploring the collection - download the first chapter of every title for free.

3 Hydrothermal Economic Dispatch Using Hybrid Big Bang-Big Crunch (HBB-BC) Algorithm

Sokun Ieng, Yusri Syam Akil, Indar Chaerah Gunadin

Department of Electrical Engineering, Hasanuddin University, Gowa 92171, Indonesia

Corresponding author: isokun5@gmail.com

Abstract: In power generation, it is expected to generate required amount of power based on the load system with minimum cost which is generally called as economic dispatch (ED). Therefore, providing an approach which can be used to solve ED problem in electric systems for effective operation is important. In this paper, hybrid big bang-big crunch (HBB-BC) algorithm was proposed to solve hydrothermal ED problem. Basically, HBB-BC is an algorithm which combined between BB-BC and PSO that use the PSO to improve ability of BB-BC algorithm. To examine the performance of HBB-BC algorithm for hydrothermal ED, IEEE 26 bus was utilized as test system with 6 generators (3 thermal and 3 hydro generator units). Next, simulation output was compared with improved PSO, and modified improved PSO algorithm. From results, HBB-BC algorithm shown the best result under tested case. It confirmed by obtained total operating cost for HBB-BC algorithm was the lowest (11,344.593 \$/h) compared to IPSO (11,451.001 \$/h) and MIPSO algorithms (11,387.000 \$/h).

Keywords: HBB-BC algorithm, economic dispatch, hydrothermal system, operating cost

10 I. Introduction

Economic dispatch (ED) is a term in electric system to achieve better operation or service to consumers. ED problem is mainly to find optimal power output of generators to minimize cost and satisfying related constraints. As the fulfillment of the condition (optimal combination) can increase the performance or effectiveness of power system operation, therefore, efforts to dealing with the problem such as providing a method which can be utilized to solve ED is important. One of the ED forms at certain power system is hydrothermal ED. In general, the objective of ED for hydrothermal system is to determine optimal output for each hydro and thermal power plants in related electric system over dispatching period to get minimum cost for fuel and satisfying related constraints. However, it is a challenging task as various data are needed and a number of constraints must be included in solving of ED problems.

A number of methods or optimization techniques are utilized for solving ED in electric systems. The methods include such as genetic algorithm [1], particle swarm optimization (PSO) [2], modified improved PSO (MIPSO) [3], modified differential evolution technique [4], firefly algorithm [5], and bat algorithm [6]. With regards to this, one of new optimization techniques is HBB-BC algorithm which was introduced by Kaveh and Talatahari in 2010 [7]. In this algorithm, it has two phases namely big bang phase (BB phase) and big crunch phase (BC phase) as in BB-BC algorithm. However in the HBB-BC algorithm, PSO is used in the BB phase to increase ability of BB-BC algorithm.

The objective of this paper is to apply the HBB-BC algorithm as an alternative approach to solve hydrothermal ED. To achieve the objective, proposed method was examined by using IEEE 26 bus system as a case study. Next, obtained result was compared with other two optimization algorithms (IPSO and MIPSO). Limited works regarding application of the HBB-BC algorithm on ED can be



found in [8-10]. In Ref [8], the authors applied HBB-BC to solve nonlinear and some different ED problems. Ref [9] applied the algorithm for optimization focus on reactive power considering losses and also voltage deviation. Meanwhile in [10], the authors utilized HBB-BC to solve non-convex ED focus on the electric system which has only thermal unit.

This paper has 5 sections: Section 1 is introduction part, Section 2 describes formulation of hydrothermal ED problem, Section 3 is an overview of applied algorithm. Next, simulation result is in Section 4, and Section 5 is the conclusion.

2. Formulation of hydrothermal ED problem

Basically, economic dispatch is a problem of optimization to make the whole system namely generator's fuel consumption or operating cost is minimum by calculating optimal power output for each generator under certain load demand condition. In general, mathematical formulation to minimize operating cost (total cost for fuel) of generator are given as follows.

For thermal units:

$$\text{Min } F_T = \sum_{i=1}^N F_i(P_i) \quad (1)$$

$$F_i(P_i) = \alpha_i + \beta_i P_i + \gamma_i P_i^2 \quad (2)$$

where F_T represents total fuel cost (\$/hr) and $F_i(P_i)$ is fuel cost for generator unit i^{th} . Meanwhile α_i , β_i , and γ_i are fuel cost coefficients, meanwhile P_i is real power output for each unit.

For hydro units:

$$q_{i,m} = a_{i,h} + b_{i,h} P_{i,mh} + c_{i,h} P_{i,mh}^2 \quad (3)$$

where $q_{i,m}$ is the rate for water flow to turbine for each hydro unit at interval m . Meanwhile $a_{i,h}$, $b_{i,h}$, and $c_{i,h}$ are fuel cost coefficients, and P_i is real power output for each hydro unit. By including power line losses and generator capacity constraints, hydrothermal ED problem can be defined as follows.

$$\sum_{i=1}^N (P_{i,h} + P_{i,t}) = P_D + P_{Loss} \quad (4)$$

And generator capacity constraints

$$P_{i,t}(max) > P_{i,t} > P_{i,t}(min) \quad (5)$$

$$P_{i,h}(max) > P_{i,h} > P_{i,h}(min) \quad (6)$$

where $P_{i,h}$ and $P_{i,t}$ are the power for each hydro and thermal generator unit, respectively. P_D is power demand and P_{Loss} is total line loss. P_{min} and P_{max} refer to minimum (lower) and maximum (upper) power limits for each generator unit. To include line losses, it is used common formula B-coefficients (B_{mn}) as in Eq. (7).

$$P_{Loss} = \sum_{m=1}^N \sum_{n=1}^N P_m B_{mn} P_n \quad (7)$$

Next, the hydrothermal ED is solved using HBB-BC algorithm as described in the next sections.

3. Overview of algorithm

3.1. BB-BC algorithm

Erol and Eksin have developed one method for optimization called big bang-big crunch (BB-BC) algorithm [11]. It is same with genetic algorithm in generating initial population randomly. However in BB-BC algorithm, it has two phases. The first one is BB phase, to create initial population in random form and then candidate solutions will spread in search space. The second one is BC phase, where the BB phase follows, it is the phase that trying to find centre of the mass for population by inverting fitness function value. The mass centre is expressed by \bar{x} as below [8].

$$\bar{x}^c = \frac{\sum_{i=1}^N \frac{1}{f^i} \bar{x}^i}{\sum_{i=1}^N \frac{1}{f^i}} \quad (8)$$

where \bar{x}^i is vector of n-dimension in search space, f^i is the value for fitness function of candidate, and N is the population size. After finding mass centre in BC phase, algorithm will find new candidate for solution (in BB phase) by new iteration using normal distribution which expressed as in Eq. (9) [9].

$$x_i^{new} = x_i^c + \frac{r\alpha(x_i^{max} - x_i^{min})}{s} \quad (9)$$

where r represents a random number, α is a parameter for search space, x_i^{max} and x_i^{min} are maximum and minimum values in designing variables, respectively. Meanwhile s is iteration step. Next iteration procedure to get convergence is repeated based on the equations above.

3.2. HBB-BC algorithm

Kaveh and Alatahari have been introduced an optimization algorithm called HBB-BC in 2010 [12]. Similar in BB-BC algorithm, the algorithm has BB phase and BC phase as well. However in the HBB-BC algorithm, PSO is applied in the BB phase to improve performance of BB-BC algorithm by increased exploration. In the algorithm, finding of new candidates by using mass centre BB-BC and best position of candidate solution (local best position $x_i^{best(k,j)}$) with best position for all particles (global best position $x_i^{gbest(k)}$) of PSO is expressed as below [10].

$$x_i^{(k+1,j)} = \beta_1 x_i^{c(k)} + (1 - \beta_1)(\beta_2 x_i^{gbest(k)} + (1 - \beta_2)x_i^{best(k,j)}) + \frac{r_i\alpha(x_i^{max} - x_i^{min})}{k+1} \quad (10)$$

where β_1, β_2 refer to adjustable parameters for controlling the influence of global and also local best respect to a new position for solution, and k is iteration number. New position for each factor can become a discrete solution which is formulated as in Eq. (11) [10].

$$x_i^{(k+1,j)} = Fix \left(\begin{array}{l} \beta_1 x_i^{c(k)} + (1 - \beta_1)(\beta_2 x_i^{gbest(k)} + (1 - \beta_2)x_i^{best(k,j)}) \\ + \frac{r_i\alpha(x_i^{max} - x_i^{min})}{k+1} \end{array} \right) \quad (11)$$

where $Fix(x)$ is round function of elements x related to allowable discrete value. So when using this function, new candidate can select nearest discrete value by using position updated formula.

3.3. Implementation of proposed algorithm

The procedure for solving hydrothermal ED using HBB-BC algorithm can be summarized as follows:

- Step 1: Input the parameter of algorithm and data of network such as generator limits (thermal and hydro units), bus data, line data, population size cost function of each unit.
- Step 2: Generate the random initial particle number depend on control parameter limited.
- Step 3: Run load flow using Newton-Raphson method to calculate fitness function for all candidates.
- Step 4: Use BC phase to find mass centre (Eq. (8)).
- Step 5: Find global best ($x_i^{gbest(k)}$) and local best ($x_i^{best(k,j)}$).
- Step 6: Generate new candidate by using Step 4 and Step 5 (Eq. (11)).
- Step 7: Check the termination condition (satisfied or not), if not repeat Step 2 to Step 6 under iteration number (increment the generation count).

4. Simulation results

Performance of HBB-BC algorithm to solve hydrothermal ED problem was tested using IEEE 26 bus system (Figure 1). In our case, generator in the system (6 generators) was divided into 3 hydro and 3

thermal units which has 46 transmission lines. For coefficients data of quadratic cost function (QCF) for each hydro generator unit (Table 1) were taken from [13]. Meanwhile coefficients of QCF for thermal generators and other data for system such as bus data and line data were taken from [14].

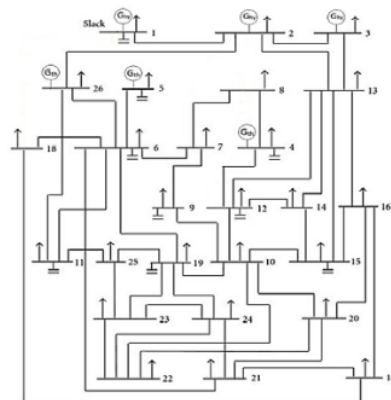

Figure 1. Single line diagram of analyzed system (IEEE 26 bus system).

Table 1. Cost function coefficient for each unit in the hydrothermal system.

Hydro (H)	Bus	a_i	b_i	c_i	$P_{min}(MW)$	$P_{max}(MW)$
1 (H1)	1	712.55	0.739499	0.00247689	100	500
2 (H2)	2	7.91027	0.395815	0.011795	50	200
3 (H3)	3	4633.69	-0.331932	0.00590656	80	300
Thermal (T)	Bus	α_i	β_i	γ_i	$P_{min}(MW)$	$P_{max}(MW)$
1 (T1)	4	200	11.0	0.0090	50	150
2 (T2)	5	220	10.5	0.0080	50	200
3 (T3)	26	190	12.0	0.0075	50	120

The used electricity load was 1263MW. In the system, bus 1, bus 2, and bus 3 were replaced with hydro generators, meanwhile bus 4, bus 5, bus 26 were still thermal generators as seen in Figure 1. In this study, used parameter values for HBB-BC algorithm to complete generate optimization system were $N = 30$, $TS = 50$, $\beta_1 = 0.4$, $\beta_2 = 0.8$ and $\alpha = 1$. Next, ED simulation results for HBB-BC algorithm and two other comparison methods (IPSO and MIPSO) are shown in Table 2.

Table 2. Comparison of optimization results between methods.

Units	Methods		
	IPSO	MIPSO	HBB-BC
H1 (MW)	489.168	485.0446	495.156
H2 (MW)	198.085	197.2800	197.609
H3 (MW)	286.513	298.2312	290.807
T1 (MW)	75.591	84.946	71.601
T2 (MW)	140.331	140.310	145.496
T3 (MW)	85.990	70.7758	74.367
Total Gen. (MW)	1,275.702	1,276.600	1,275.036
Total Load (MW)	1,263.000	1,263.000	1,263.000
Total loss (MW)	12.678	13.588	12.036
Total Cost (\$/h)	11,451.001	11,387.000	11,344.593

It can be seen from the table that performance of HBB-BC is better than other two algorithms. It is confirmed by obtained total cost for HBB-BC is lower (11,344.593 \$/h) than IPSO (11,451.001 \$/h) and MIPSO (11,387.000 \$/h). Total power loss for HBB-BC is 12.036 MW, this result is better than IPSO (12.678 MW) and MIPSO algorithm (13.588 MW). To meet the load, hydro units produced more electric power than thermal units which make total cost reduced as power cost for hydro units are cheaper than thermal units. It is a sign that the using of HBB-BC algorithm for hydrothermal ED is working well in finding optimum best power output. It gives more advantageous as an alternative for optimization tool. Figure 2 presents convergence characteristic of HBB-BC algorithm to get best solution. From results of simulation with 100 iterations, the cost starts to stable from 13 iterations which shown the powerful of proposed algorithm in using local best and global best of PSO in generating new candidates. Next, Figure 3 presents solution of new candidates (output for hydro unit and thermal unit) to find minimum cost.

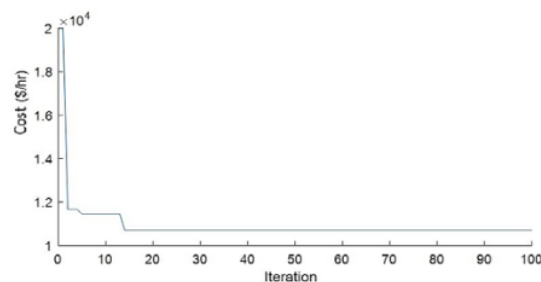

Figure 2. The plot of ED of the hydrothermal system with HBB-BC algorithm.

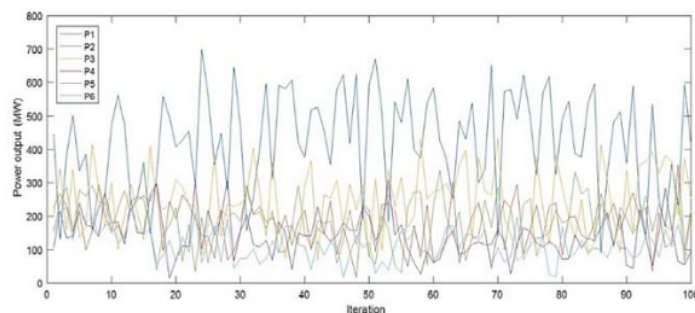

Figure 3. The candidate output for generator units.

5. Conclusion

This research presents HBB-BC algorithm as optimization tool to solve hydrothermal ED problem. Standard IEEE 26 bus system was used as a case study, and performance of the algorithm was compared with two other algorithms (IPSO and MIPSO). From comparison of results, it is concluded that HBB-BC method given better performance than other methods. It shown by obtained total operating cost and losses for HBB-BC method were the lowest. Therefore, the proposed HBB-BC method to solve hydrothermal ED case is favorable and more robust in providing better solution. It is promising to solve more complicated ED problems in electric systems.

6. References

- [1] Warsono, King, D. J., Özveren. C. S., Bradley, D. A. (2007). Economic load dispatch optimization of renewable energy in power system using genetic algorithm. *Power Tech* (Lausanne, Switzerland)
- [2] Park, J., Lee, K., Shin J, and Lee, K. Y. (2005). A particle swarm optimization for economic dispatch with nonsmooth cost functions. *IEEE Trans. Power Syst.* **20** 34–42
- [3] Humena S., Manjang S., Gunadin I. C. (2016). Optimization economic power generation using modified improved PSO algorithm methods. *Journal of Theoretical and Applied Information Technology* **93**(2) 522-530
- [4] Xuemin, W., Anqiang, L., Rui, Z. (2017). A research on short-term hydro-wind economic dispatch problem simulated with a modified differential evolution algorithm. *IOP Conf. Ser.: Mater. Sci. Eng.* **199** 012031
- [5] Nema, P., Gajbhiye, S. (2014). Application of artificial intelligence technique to economic load dispatch of thermal power generation unit. *International Journal of Energy and Power Engineering* **3**(6-2) 15-20
- [6] Biswal, S., Barisal, A. K., Behera, A., Prakash. T. (2013). Optimal power dispatch using bat algorithm. *International Conference on Energy Efficient Technologies for Sustainability* (Nagercoil, India) 1018-1023
- [7] Kaveh A., Talatahari, S.(2010). Optimal design of schwedler and ribbed domes via hybrid big bang – big crunch algorithm. *Journal of Constructional Steel Research* **66** 412-419
- [8] Labbi, Y., Attous, D.B. (2016). A hybrid big bang-big crunch optimization algorithm for solving the different economic load dispatch problems. *Int J Syst Assur Eng Manag.* **8**(2) 275-286
- [9] Sakthivel, S., Manimaran, S., Deepa, V., Priya A., Suganya, A., Indumathi, S. (2017). Hybrid big bang – big crunch algorithm for optimal reactive power dispatch by loss and voltage deviation minimization. *International Journal of Engineering Trends and Technology* **45**(8) 404-410
- [10] Shahinzadeh, H., Fathi, S. H., Moazzami, M., Hosseinian, S.H.(2017). Hybrid big bang – big crunch algorithm for solving non-convex economic load dispatch problems. *2nd Conference on Swarm Intelligence and Evolutionary Computation* (Iran) 48-53
- [11] Erol, O. K., Eksin, I.(2006). A new optimization method: Big Bang–Big Crunch *Advances in Engineering Software* **37** 106–111
- [12] Kaveh, A., Talatahari, S. (2009). Size optimization of space trusses using big bang – big crunch algorithm. *Computers and Structures* **87** 1129-1140
- [13] Kimball, L. M., Clements, K. A., Davis, P. W., Nejdawi, I. (2002). Multiperiod hydrothermal economic dispatch by an interior point method. *Mathematical Problems in Engineering* **8** 33-42
- [14] Saadat, H. (2010). *Power System Analysis (Third Edition)*, PSA Publishing (United States of America) chapter 7 pp 339-348

Hydrothermal Economic Dispatch Using Hybrid Big Bang-Big Crunch (HBB-BC) Algorithm

ORIGINALITY REPORT

17%

SIMILARITY INDEX

15%

INTERNET SOURCES

18%

PUBLICATIONS

%

STUDENT PAPERS

PRIMARY SOURCES

1	repository.unsri.ac.id Internet Source	7%
2	eprints.umpo.ac.id Internet Source	2%
3	www.proceedings.com Internet Source	1%
4	por.stkipkusumanegara.ac.id Internet Source	1%
5	Q. H. Wu, W. J. Tang, S. He, Y. J. Cao. "Dispatching", Wiley, 1999 Publication	1%
6	thesis.univ-biskra.dz Internet Source	1%
7	Hossein Shahinzadeh, S. Hamid Fathi, Majid Moazzami, Seyed Hossein Hosseinian. "Hybrid Big Bang-Big Crunch Algorithm for solving non-convex Economic Load Dispatch problems", 2017 2nd Conference on Swarm	1%

Intelligence and Evolutionary Computation (CSIEC), 2017

Publication

8

Nazmul Siddique, Hojjat Adeli. "Physics-based search and optimization: Inspirations from nature", Expert Systems, 2016

Publication

9

Kaveh, A.. "Size optimization of space trusses using Big Bang-Big Crunch algorithm", Computers and Structures, 200909

Publication

10

Cai, J.. "Chaotic ant swarm optimization to economic dispatch", Electric Power Systems Research, 200708

Publication

11

S. Ahmadi, Sh. Abdi. "Optimal reconfiguration of unbalanced distribution systems using a new hybrid Big Bang-Big Crunch algorithm for loss reduction", 2015 20th Conference on Electrical Power Distribution Networks Conference (EPDC), 2015

Publication

12

Hakam Singh, Yugal Kumar. "Cellular Automata Based Model for E-Healthcare Data Analysis", International Journal of Information System Modeling and Design, 2019

Publication

1 %

1 %

1 %

1 %

1 %

Exclude quotes Off

Exclude matches < 1%

Exclude bibliography On